

**SECTION VIEW**

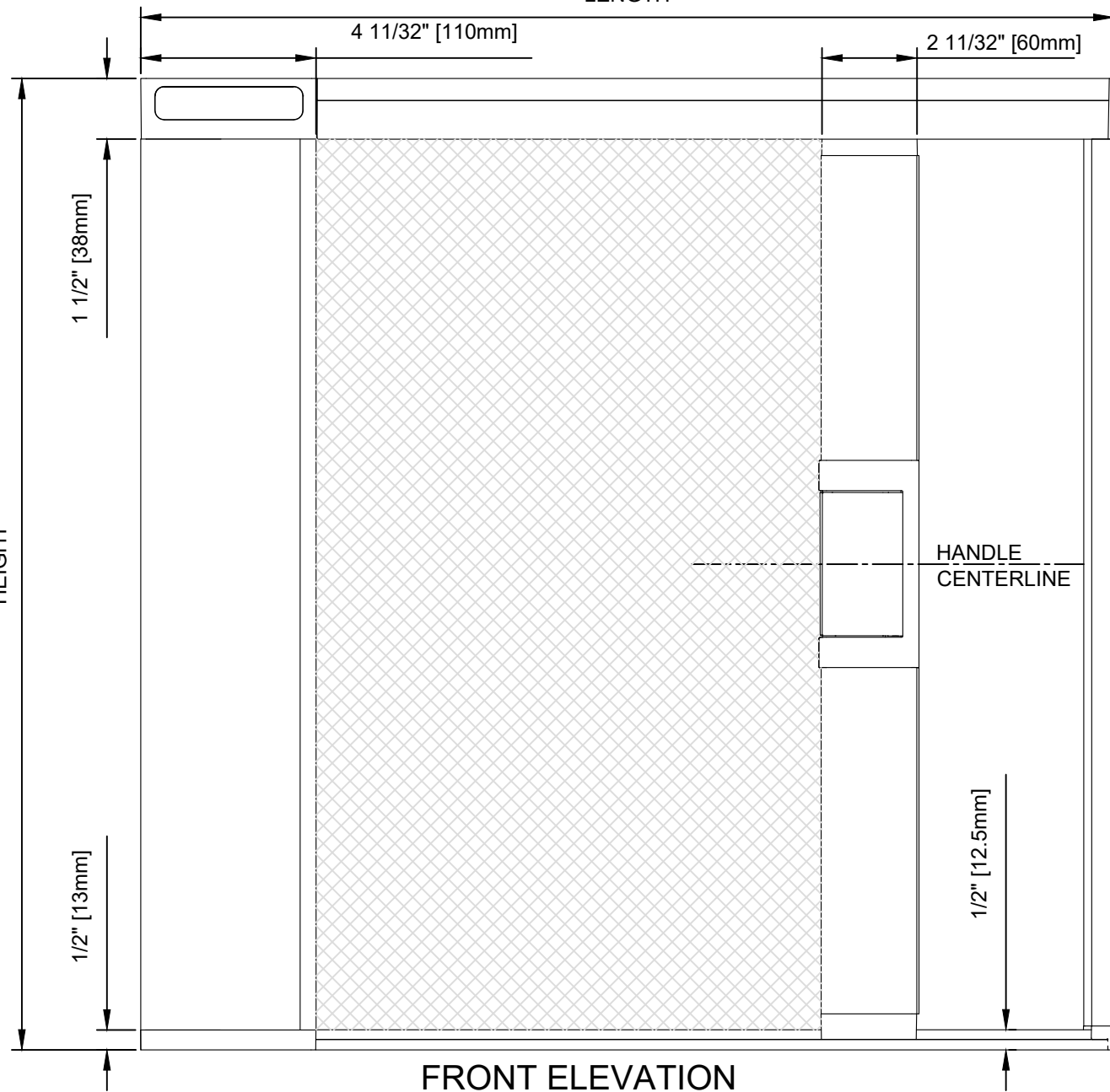

**FRONT ELEVATION**

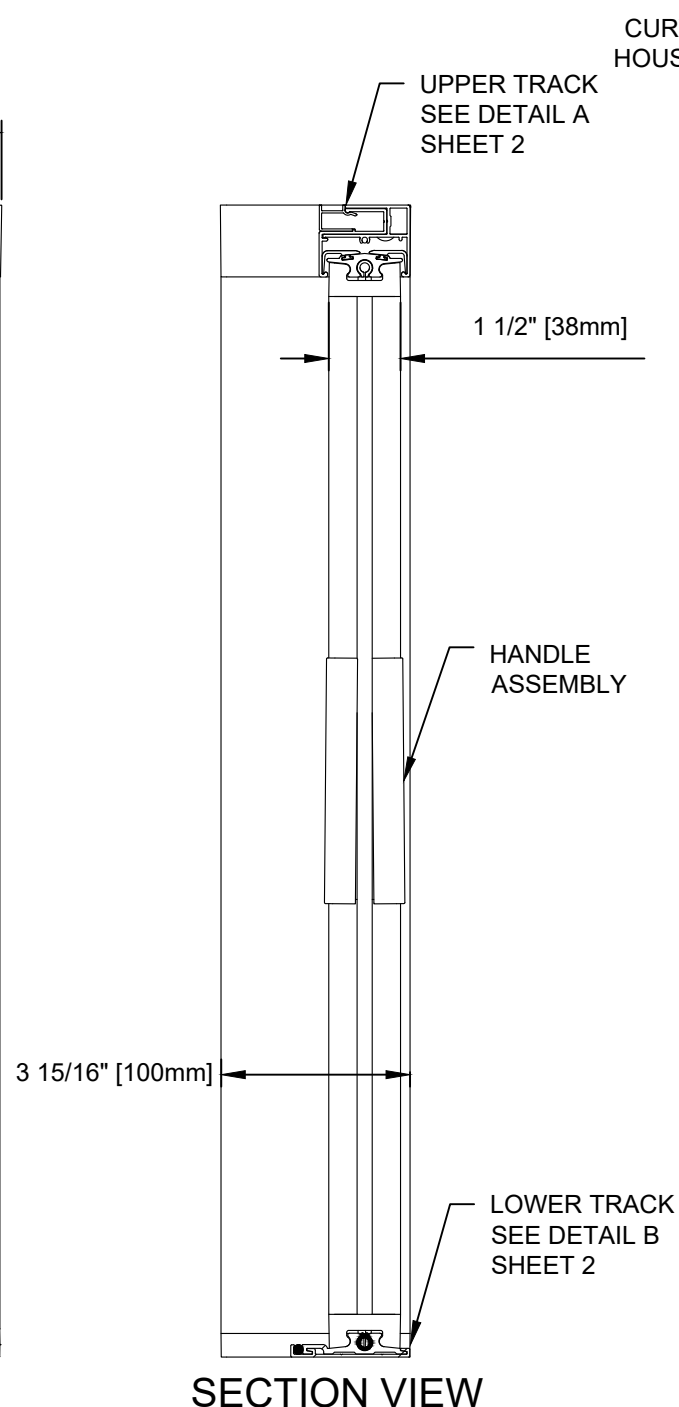

**SECTION VIEW**

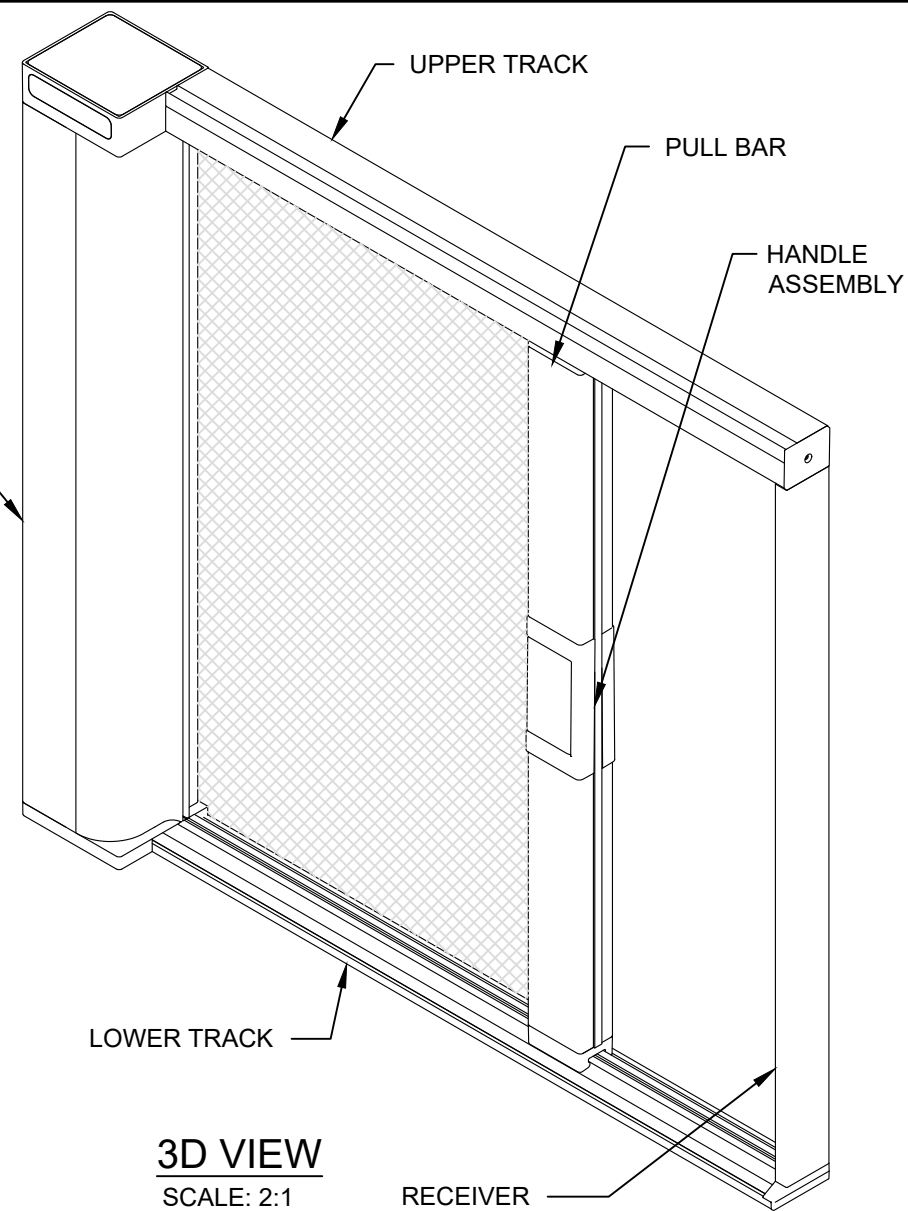

**3D VIEW**  
SCALE: 2:1

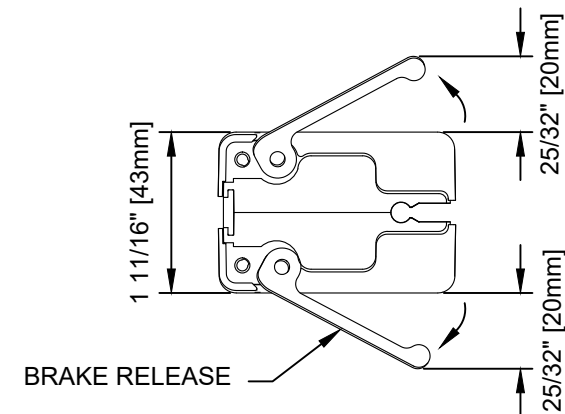

**HANDLE ASSEMBLY - EXTENDED**  
SCALE: 6"=1'0"



**WIZARD INDUSTRIES INC.**  
4263 PHILLIPS AVENUE  
BURNABY, BC  
V5A 2X4

**THE HORIZON**  
100mm ASSEMBLY

SCALE:  
3:1  
DATE:  
MAY 1 2019  
DWG:  
HOR-030