

4" STANDARD CENTRE CORE

SCALE: 3" = 1'-0"
WEIGHT: 1.8 lb/ft

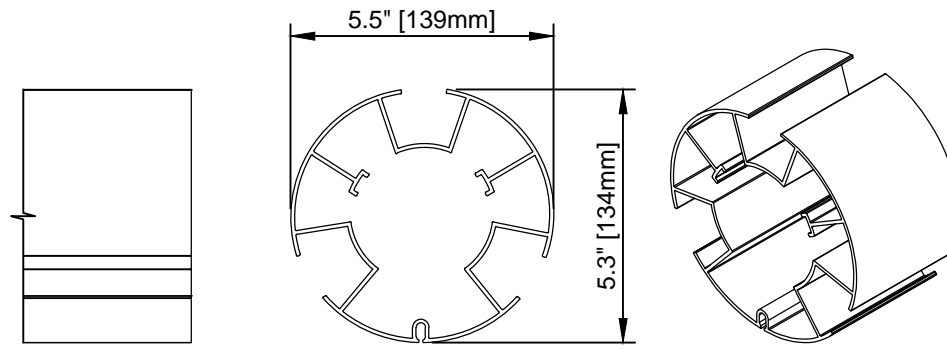

5 1/2" OPTIONAL CENTRE CORE

SCALE: 3" = 1'-0"
WEIGHT: 2.8 lb/ft

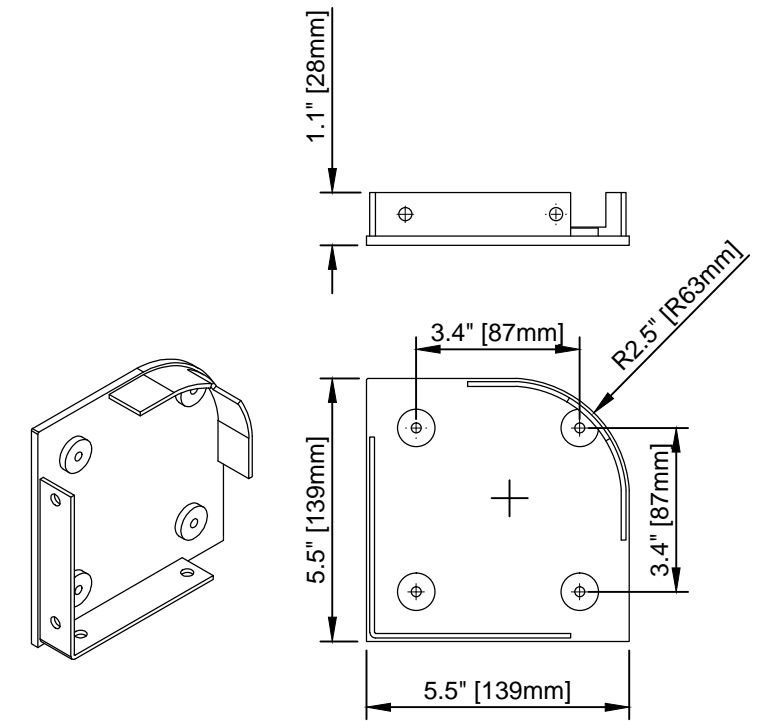

END CAP

SCALE: 3" = 1'-0"
WEIGHT: 0.75 lb

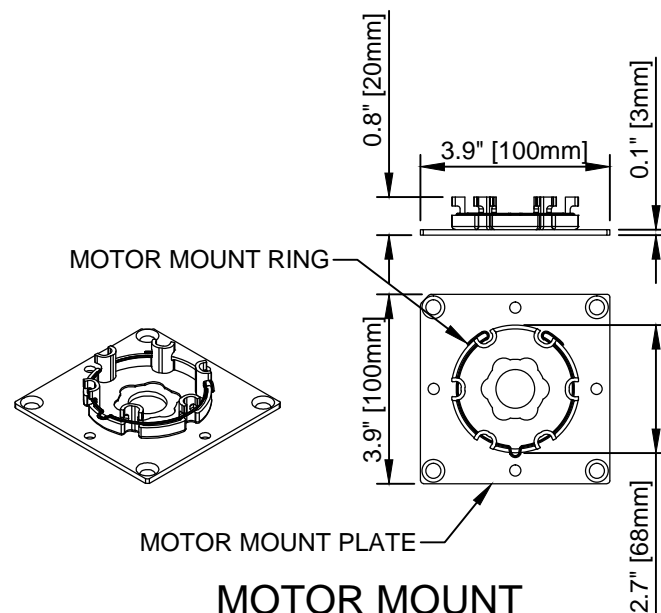

MOTOR MOUNT

SCALE: 3" = 1'-0"
WEIGHT: 0.63 lb

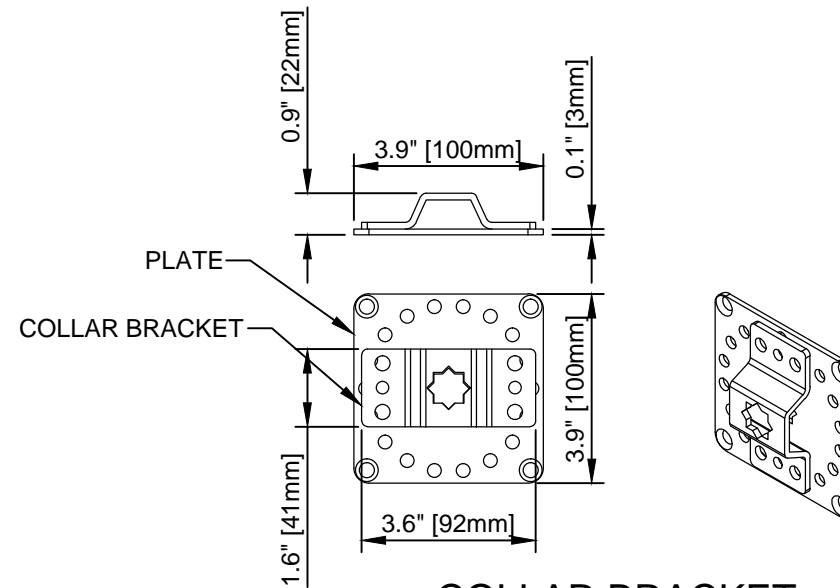

COLLAR BRACKET

SCALE: 3" = 1'-0"
WEIGHT: 0.75 lb

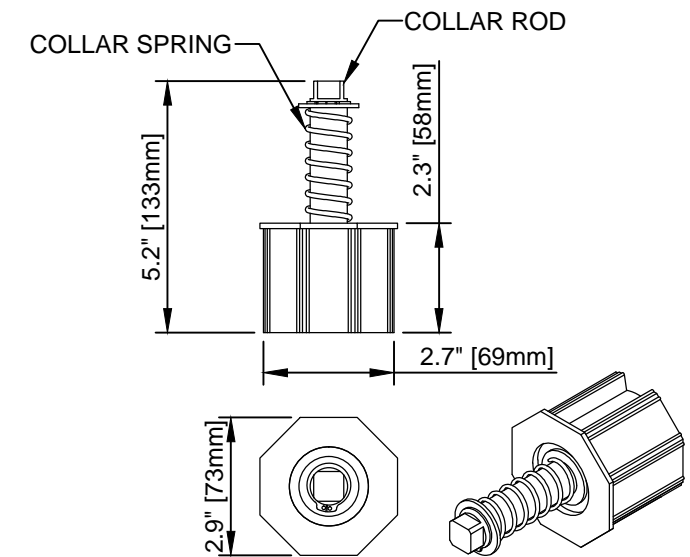

COLLAR

SCALE: 3" = 1'-0"
WEIGHT: 1.25 lb



WIZARD INDUSTRIES INC.
4263 PHILLIPS AVENUE
BURNABY, BC
V5A 2X4

**MOTORIZED RETRACTABLE
WALL SCREEN COMPONENTS**

SCALE:
AS SHOWN
DATE:
AUG. 03 2018
DWG:
MS-002